

 **CLEAN ROOM DEVICES, INC.**

## **CRD130 TUBING CUTTER**

### **OPERATIONS MANUAL**

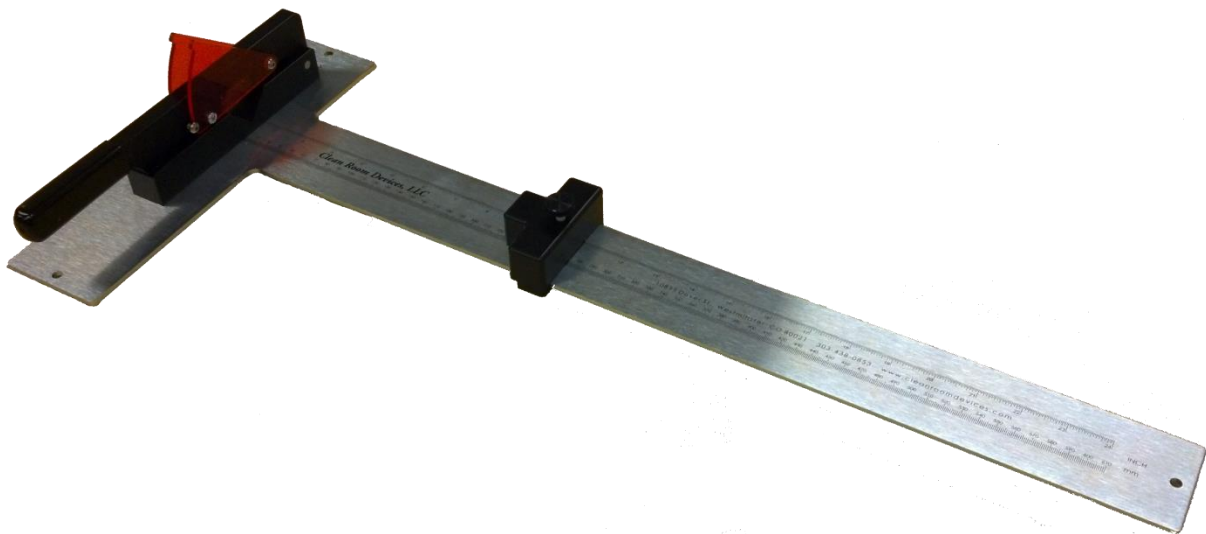

VERSION 2.2  
LAST EDITED 06.22.2022  
[cleanroomdevices.com](http://cleanroomdevices.com)

# Table of Contents

- Title Page.....1
- Table of Contents.....2
- 1.0 General Product & Safety Information.....3
  - 1.1 Product Information
  - 1.2 Safety Information
- 2.0 Installation.....3
- 3.0 Operation.....4
- 4.0 Troubleshooting.....4
- 5.0 Maintenance.....4
  - 5.1 Blade Replacement
  - 5.2 Periodic Cleaning
- 6.0 Product Specifications.....5
- 7.0 Durometer Scale.....5
- 8.0 Replacement Parts List.....6
- 9.0 Warranty.....7
  - 9.1 Warranty
  - 9.2 Warranty Period

## 1.0 General Product & Safety Information

### 1.1 Product Information

- The CRD130 Tubing Cutter is designed to cut flexible tubing (including heatshrink) up to 90 durometer, shore A, including any non-metallic braided materials. The cutter will cut a maximum diameter of 3/4"
- The minimum/maximum cut lengths range from 5/8" to 24" long. All lengths within that range can be achieved within plus/minus .030" tolerance utilizing the slide block and scale.

### 1.2 Safety Information

- This product uses a chevron blade cutting knife that is extremely sharp. Use care when opening the cutter handle.  
Replacements blades are available from Clean Room Devices, LLC.

<b>WARNING</b>
----------------

*Pay close attention to where your hands are when the cutter is open as the cutter blade is exposed and is extremely sharp.*

*When the cutter is not in use keep the the cutter handle closed.*

## 2.0 Installation

- Ensure all four (4) rubber feet are completely stabilized on your work surface prior to using the cutter. The cutter is to be place on a flat even surface.

### 3.0 Operation

- Position the slide block to the desired cut length using the scale and tighten the thumbscrew.
- Open the cutter handle with you left hand, with your right hand pull the tubing through the cutter cradle to the slide block. Pull down the cutter handle with your left hand.
- Remove the cut tubing.

### 4.0 Troubleshooting

Operating Error	Action
Cutting blade makes bad cuts or leaves burrs.	<ol style="list-style-type: none"><li>1. Ensure the tubing being cut does not exceed the recommended durometer.</li><li>2. Check the cutting blade for wear or damage and possible replacement.</li></ol>
Slide block does not move in either direction.	<ol style="list-style-type: none"><li>1. Fully loosen the thumb screw to slide.</li><li>2. Visually inspect the slide path for dirt or debris. Clean as required.</li></ol>

### 5.0 Maintenance

#### 5.1 Blade Replacement

- Lift the cutter handle all the way back. You now have access to the cutting blade, loosen the (2) screws that sandwich the blade between the spacer bar and the cutter handle. Using a magnet tipped screwdriver grab the blade and remove the screws completely. Take this opportunity to blow out any debris found within the cutter housing.

<b>WARNING</b>
----------------

**Although the blade may require replacement it remains extremely sharp, handle with care. To avoid injury, proper disposal is highly recommended.**

- Install the new knife blade using a magnetic tipped screwdriver and reusing the same screws. Ensure the blade is centered and positioned on the mounting block properly.
- The knife blade screws should be checked periodically for tightness.

### 5.2 Periodic Cleaning

- Wipe down outer surfaces with alcohol, septihol or mild detergents, specifically those surfaces/grooves that come in contact with the sliding block.
- Inspect the cutter V cradle and blow-out any/all debris.

## 6.0 Product Specifications

Unit Weight	5 LBS / 2.27 KG
Overall Dimensions	28-1/8" L x 11" W x 4-1/4" H

## 7.0 Durometer Scale

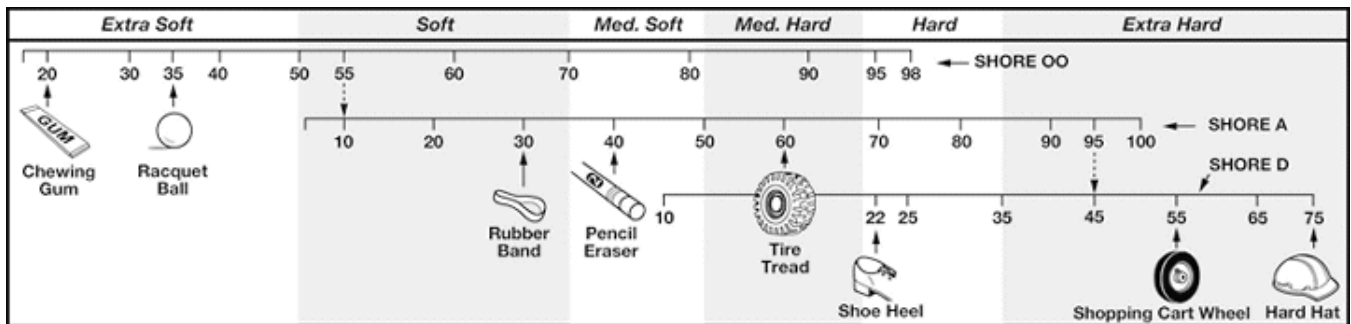

## 8.0 Parts List

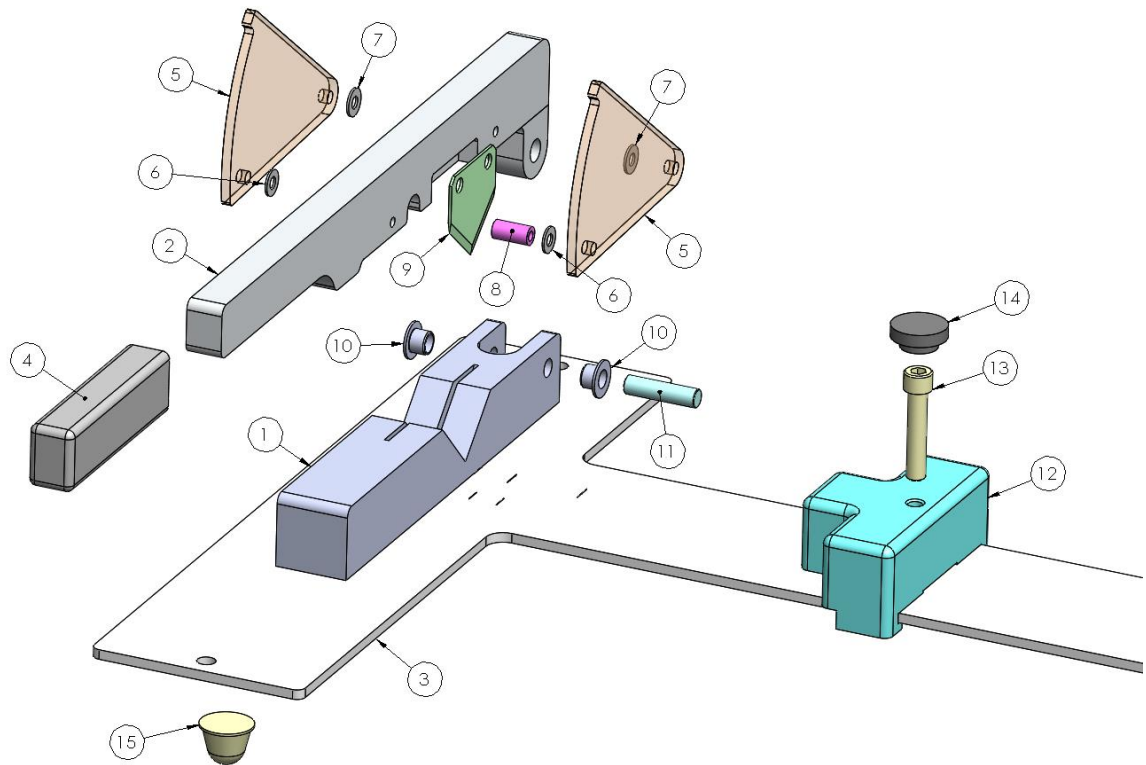

Item	Part Number	Description
1	CD130-009	Cutter Base
2	CD130-010	Cutter Handle
3	CD130-006	Zinc Plated Steel Base
4	P00353	Handle Cover
5	CD135-001	Rotating Guard
6	P00102	4mm SS Washer
7	P00436	Wear Resistant Acetal Flat Washer
8	P00441	Threaded Female Round Standoff
9	CB100	Chevron Blade
10	P00351	Plastic Bearing
11	P00350	1/4" x 1" Stainless Steel Dowel Pin
12	CD130-008	Slide Block
13	P00346	1/4-20 x 1-1/4" Nylon Screw
14	P00347	Plastic Screw Head
15	P00348	Rubber Feet

## 9.0 Warranty

### 9.1 Warranty

The manufacturer warrants the product manufactured by it, when properly installed, operated, applied and maintained in accordance with the procedures and recommendations outlined in the manufacturer's operation manual, to be free from defects in material or workmanship for a period as specified below, provided such defect is discovered and brought to the manufacturer's attention within the stated warranty period.

The manufacturer will repair or replace any product or part determined to be defective by the manufacturer within the warranty period, provided such defect occurred in the normal service and not as a result of misuse, abuse, neglect or accident. Normal maintenance items requiring routine replacement are not warranted. The warranty covers parts and labor for the warranty period unless otherwise specified. Repair or replacement shall be made at the factory or the installation site, at the sole discretion of the manufacturer. Any service performed on the product by anyone other than the manufacturer must first be authorized by the manufacturer.

Unauthorized service voids the warranty and any resulting charge or subsequent claim will not be paid. Products repaired or replaced under warranty shall be warranted for the unexpired portion of the warranty applying to the original product.

The foregoing is the exclusive remedy of any buyer of the manufacturer's product. The maximum damages liability for the manufacturer is the original purchase price of the product or part.

THE FOREGOING WARRANTY IS EXCLUSIVE AND IN LIEU OF ALL OTHER WARRANTIES, WHETHER WRITTEN, ORAL, OR STATUTORY, AND IS EXPRESSLY IN LIEU OF THE IMPLIED WARRANTY OF MERCHANTABILITY AND THE IMPLIED WARRANTY OF FITNESS FOR A PARTICULAR PURPOSE. THE MANUFACTURER SHALL NOT BE LIABLE FOR LOSS OR DAMAGE BY REASON OF STRICT LIABILITY IN TORT OR ITS NEGLIGENCE IN WHATEVER MANNER INCLUDING DESIGN, MANUFACTURE OR INSPECTION OR THE EQUIPMENT OR ITS FAILURE TO DISCOVER, REPORT, REPAIR, OR MODIFY LATENT DEFECTS INHERENT THEREIN.

THE MANUFACTURER, HIS REPRESENTATIVE OR DISTRIBUTOR SHALL NOT BE LIABLE FOR LOSS OF USE OF THE PRODUCT OR OTHER INCIDENTAL OR CONSEQUENTIAL COSTS, EXPENSES, OR DAMAGES INCURRED BY THE BUYER, WHETHER ARISING FROM BREACH OF WARRANTY, NEGLIGENCE OR STRICT LIABILITY IN TORT.

The manufacturer does not warrant any product, part, material, component, or accessory manufactured by others and sold or supplied in connection with the sale of manufacturer's products.

### 9.1 Warranty Period

Parts and labor are for ninety (90) days from the date of shipment from the factory. Freight to the factory on units that the manufacturer requests to be returned shall be paid by the purchaser, all return freight to be paid by the manufacturer; means of transportation to be specified by the manufacturer.

*For additional information contact: [www.cleanroomdevices.com](http://www.cleanroomdevices.com)*

Clean Room Devices, Inc.  
10855 Dover Street, Suite 100  
Westminster, CO 80021  
303-438-0853