

| REVISIONS |      |                 |        |          |
|-----------|------|-----------------|--------|----------|
| ZONE      | REV. | DESCRIPTION     | DATE   | APPROVED |
|           | A    | INITIAL RELEASE | 3/1/21 | MSC      |

WALL THICKNESS MUST BE 4 7/8" +/- 1/8"

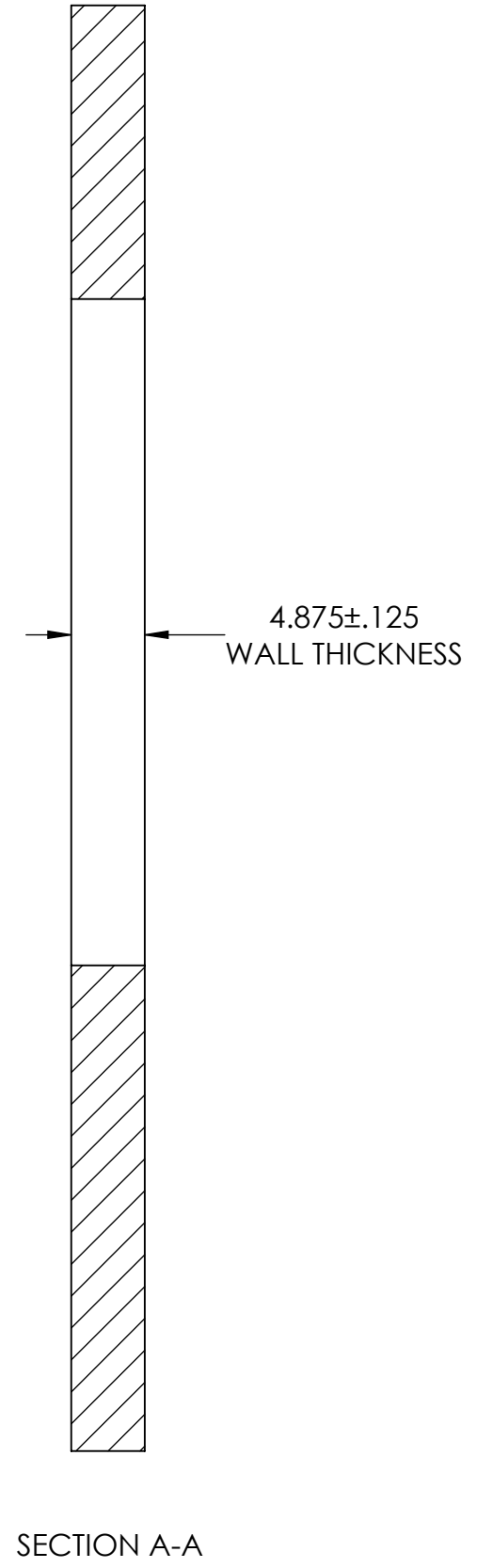
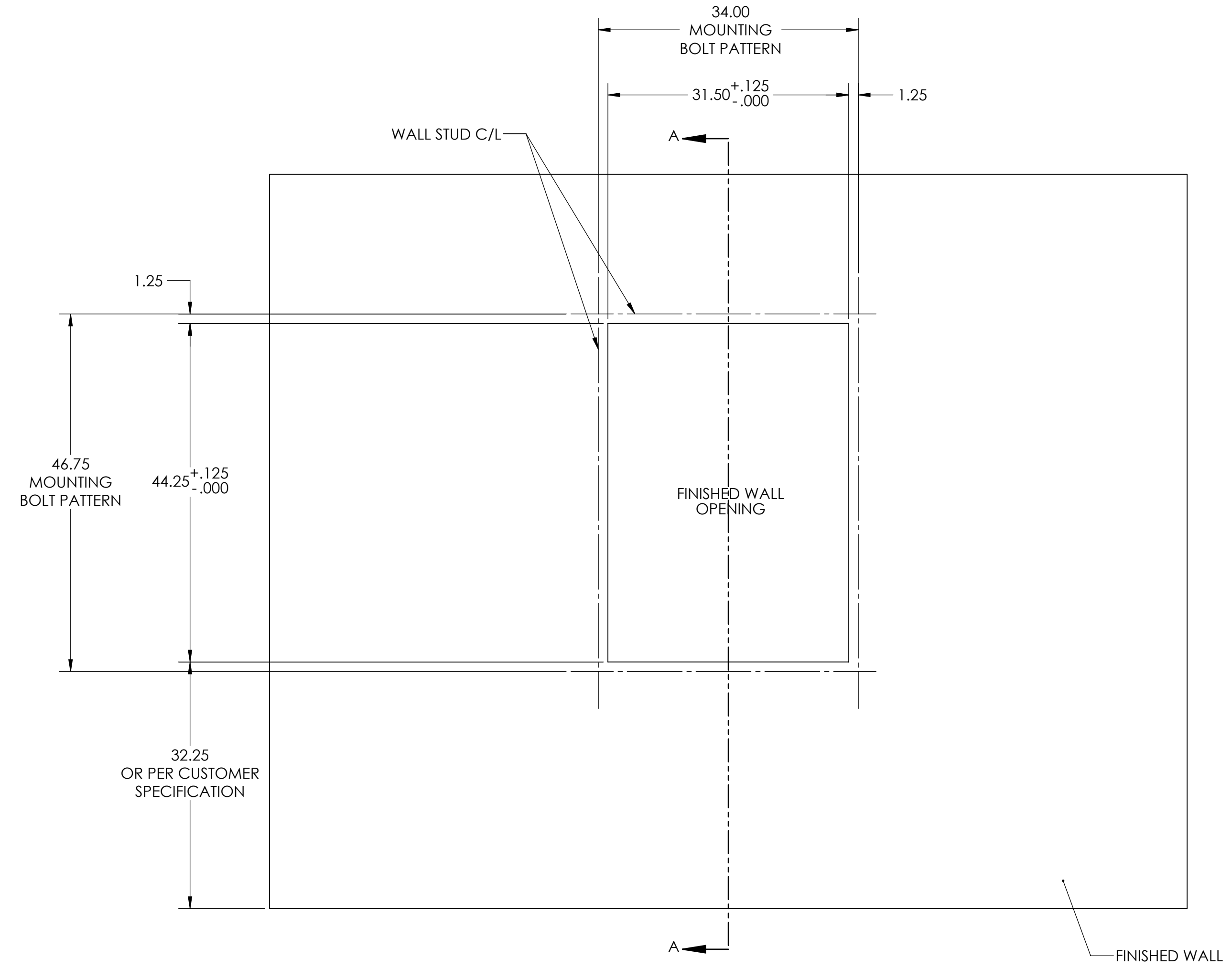

- NOTES:
1. WALL STUDS SHOULD BE CENTERED ON THE BOLT PATTERN CENTERLINES TO SUPPORT THE PASS-THRU WINDOW
  2. OVERALL WALL THICKNESS SHOULD BE 4.875 +/- .125".

**PROPRIETARY AND CONFIDENTIAL**  
 THE INFORMATION CONTAINED IN THIS DRAWING IS THE SOLE PROPERTY OF CLEAN ROOM DEVICES, LLC. ANY REPRODUCTION IN PART OR AS A WHOLE WITHOUT THE WRITTEN PERMISSION OF CLEAN ROOM DEVICES, LLC IS PROHIBITED.

|           |         |   |           |      |           |  |
|-----------|---------|---|-----------|------|-----------|--|
|           |         | UNLESS OTHERWISE SPECIFIED:                     | DRAWN     | NAME | DATE      | CLEAN ROOM DEVICES, LLC                        |
|           |         | DIMENSIONS ARE IN INCHES                        | CHECKED   | MSC  | 3/1/21    |  |
|           |         | TOLERANCES:                                     | ENG APPR. |      |           |  |
|           |         | FRACTIONAL ±1/16                                | MFG APPR. |      |           |  |
|           |         | ANGULAR: MACHINED ±0.5°<br>BEND ±2°             | Q.A.      |      |           |  |
|           |         | TWO PLACE DECIMAL ±.01                          | COMMENTS: |      |           | TITLE:<br><b>FINISHED WALL OPENING, CRD343</b> |
|           |         | THREE PLACE DECIMAL ±.005                       |           |      |           |  |
|           |         | INTERPRET GEOMETRIC TOLERANCING PER: ANSI Y14.5 | MATERIAL  |      | SEE NOTES | SIZE   |
|           |         |   | FINISH    |      | SEE NOTES | DWG. NO.                                       |
| NEXT ASSY | USED ON |   |           |      |           | REV  |
|           |         |   |           |      |           | <b>C</b>                                       |
|           |         |   |           |      |           | <b>343-005</b>                                 |
|           |         |   |           |      |           | <b>A</b>                                       |
|           |         |   |           |      |           | SCALE: 1:12                                    |
|           |         |   |           |      |           | WEIGHT:  |
|           |         |   |           |      |           | SHEET 1 OF 1                                   |